



DOMINATOR PUMPS

MEDIUM HEAD & HIGH HEAD

*High Performance
Pumps for
Pools & Spas*

The new standard in quiet pumps

LOW NOISE • HIGH PERFORMANCE

- 1 Positive Seal Trap Lid
- 2 Locked-In Strainer Basket
- 3 Quick Release Compression Fittings
- 4 Glass Reinforced Engineering Grade Polymer Construction
- 5 Long Life Shaft Seal
- 6 Built-In Overload Protector
- 7 Corrosion Proof Base
- 8 Stainless Steel Fasteners
- 9 Strainer Basket Below Suction Inlet



3
YEAR
WARRANTY

Dominator EQUIPMENT

Dominator High Performance Pumps

Available in Medium Head or High Head models, Poolrite's Dominator Pumps are precision built and designed to deliver high performance in applications where higher than normal head pressure conditions exist. Constructed of glass reinforced engineering grade polymer, these pumps are durable, lightweight and corrosion proof. Each pump is individually tested to assure quiet hassle-free performance.

- Utilises an industrial, Square Flange Motor.
- Unique Trap Design provides a positive seal and allows easy access.
- Quick Release Compression Fittings for easy installation or maintenance.

- Poolrite's drip proof, cool running seal virtually eliminates seal burn out.
- Available in .75 H.P. (Medium Head only), 1 H.P., 1.25 H.P. and 1.5 H.P.



Dominator Pumps provide the performance you demand and are backed by over 30 years experience and proven product reliability.

PERFORMANCE CURVES

MEDIUM HEAD

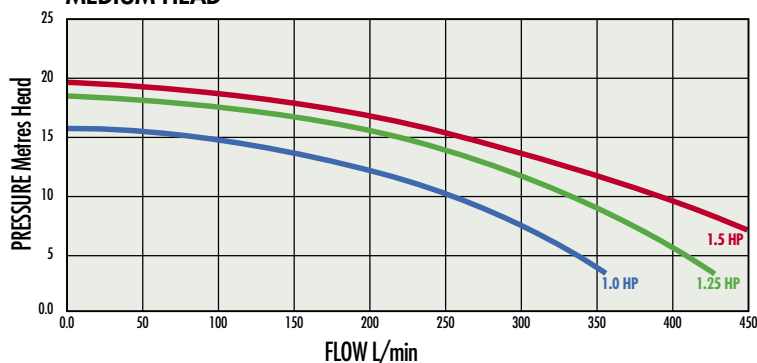

HIGH HEAD (Ideal for infloor cleaning systems)

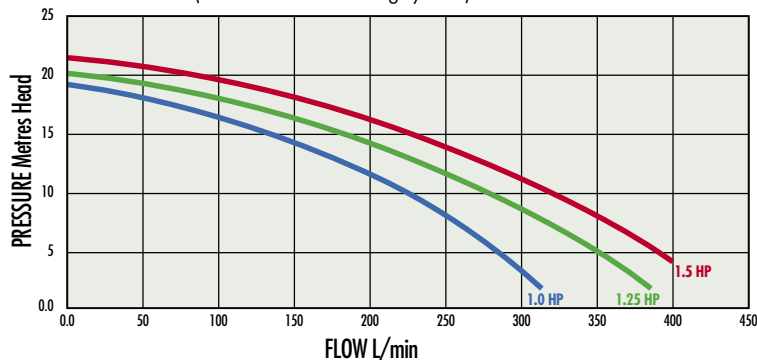

CAPACITY IN LITRES PER MINUTE

Curve based on 2800 RPM impeller speed, 60 cycle units available

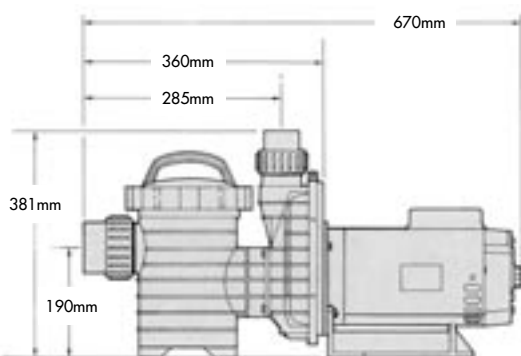
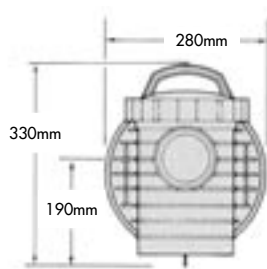

Warranty: 3 years from date of purchase. 12 months on mechanical seal.

For good clean fun!



Get it right!

AUSTRALIA
HEAD OFFICE – QLD: 415 Creek Road MT GRAVATT 4122
 Telephone: (07) 3323 6555, Fax: (07) 3323 6500

Nth QLD: 36 Hugh Ryan Drive GARBUTT 4814
 Telephone: (07) 4779 4880, Fax: (07) 4779 6714

NSW: 6 Forsyth Close WETHERILL PARK 2164
 Telephone: (02) 9729 0166, Fax: (02) 9729 2759

VIC: 1 Endeavour Way BRAESIDE 3195
 Telephone: (03) 9588 1770, Fax: (03) 9588 1779

WA: 16 Ledger Road BALCATT 6021
 Telephone: (08) 9344 3871, Fax: (08) 9345 3923

NEW ZEALAND
 22/761 Great South Road, Penrose AUCKLAND
 Telephone (09) 571 0210, Fax: 0800 766 574

Manufactured by Poolrite Equipment Pty Ltd ABN 11 001 674 004 Website: www.poolrite.com.au Email: info@poolrite.com.au

Manufacturer reserves the right to alter specifications without notice.