



EQUIPMENT

DIATOMACEOUS EARTH FILTER

DOMESTIC/COMMERCIAL

Filter systems
for Micro-Clean
Water

POOL AND SPA FILTERS



Diatomaceous Earth Filters

Features:

- Titan XL Range filter tanks are injection-moulded in new "Engineering Polymer". The most advanced material for this application enabling POOLRITE to give an extended 10-Year Warranty on filter tanks.
- POOLRITE'S exclusive square "Candlestick" septum construction covered with "Rapid Flow" tubular terylene material provides extra-long filter cycles and efficient backwashing.
- The complete new design "Multifunction" control valve is extremely easy to operate and is totally maintenance-free.
- The inbuilt sight glass gives positive indication when backwashing is completed – eliminates guess work and waste of pool water.
- All systems are fitted with the proven high performance POOLRITE PUMPS – featuring corrosion-resistant design.
- Fully warranted for use with POOLRITE SUPERCHLOR Automatic Saline Chlorinator and other approved brands.
- Australian design and manufacture is your guarantee of continued after-sales back-up.



XL-60, XL-50, XL-40

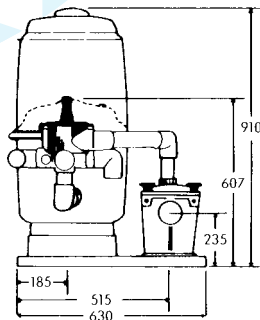

XL-60, XL-50, XL-40, XL-35

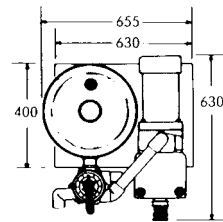

XL-60, XL-50, XL-40, XL-35

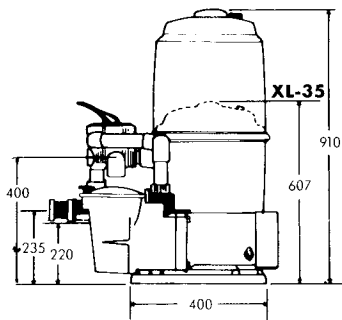

SPECIFICATION FOR DUAL FILTER SYSTEMS

RANGE	AV. FLOW RATE PER HOUR CLEAN FILTER (LITRES)	POOL SIZE 6 HOUR TURNOVER (LITRES)	POOL SIZE 8 HOUR TURNOVER (LITRES)	POOLRITE PUMP MODEL	PUMP MOTOR H.P. (KW)
DUAL XL-40	19,930	119,580	159,440	SQ 600	1.50 (1.10)
DUAL XL-50	24,600	147,600	196,800	SQ 700	2.0 (1.50)
DUAL XL-60	24,600	147,600	196,800	SQ 700	2.0 (1.50)

PERFORMANCE SPECIFICATION CHART

RANGE	AV. FLOW RATE PER HOUR CLEAN FILTER (LITRES)	POOL SIZE 6 HOUR TURNOVER (LITRES)	POOL SIZE 8 HOUR TURNOVER (LITRES)	DIATOMACEOUS EARTH WEIGHT (GRAMS)	POOLRITE PUMP MODEL	PUMP MOTOR H.P. (KW)
XL 30	9,900	59,400	79,200	736	SF 550	.75 (0.55)
XL 40	15,600	93,600	124,800	910	SQ 400	1.0 (0.75)
XL 50	18,000	108,000	144,000	1130	SQ 500	1.25 (0.93)
XL 60	19,930	119,580	159,440	1360	SQ 600	1.50 (1.10)
XL 80	19,930	119,580	159,440	1530	SQ 600	1.50 (1.10)



10 YEAR WARRANTY:

- 5 years full warranty from date of purchase on filter tank only.
- For an additional 5 years the filter tank will be repaired or replaced at pro-rata cost.
- All other components carry 12 months warranty.



EQUIPMENT

For good clean fun!

NSW: 6 Forsyth Close WETHERILL PARK 2164
Telephone: (02) 9729 0166, Fax: (02) 9729 2759

VIC: 1 Endeavour Way BRAESIDE 3195
Telephone: (03) 9588 1770, Fax: (03) 9558 1779

WA: 16 Ledger Road BALCATTIA 6021
Telephone: (08) 9344 3871, Fax: (08) 9345 3923

NEW ZEALAND
22/761 Great South Road, Penrose AUCKLAND
Telephone (09) 571 0210, Fax: 0800 766 574

AUSTRALIA
HEAD OFFICE – QLD: 415 Creek Road MT GRAVATT 4122
Telephone: (07) 3323 6555, Fax: (07) 3323 6500

Nth QLD: 36 Hugh Ryan Drive GARBUTT 4814
Telephone: (07) 4779 4880, Fax: (07) 4779 6714

Manufactured by Poolrite Equipment Pty Ltd ABN 11 001 674 004 Website: www.poolrite.com.au Email: info@poolrite.com.au

Manufacturer reserves the right to alter specifications without notice.